

PATHWAY TO 2020/2021 GRAND FINAL TUESDAY MIXED DIV 1,2 & 3

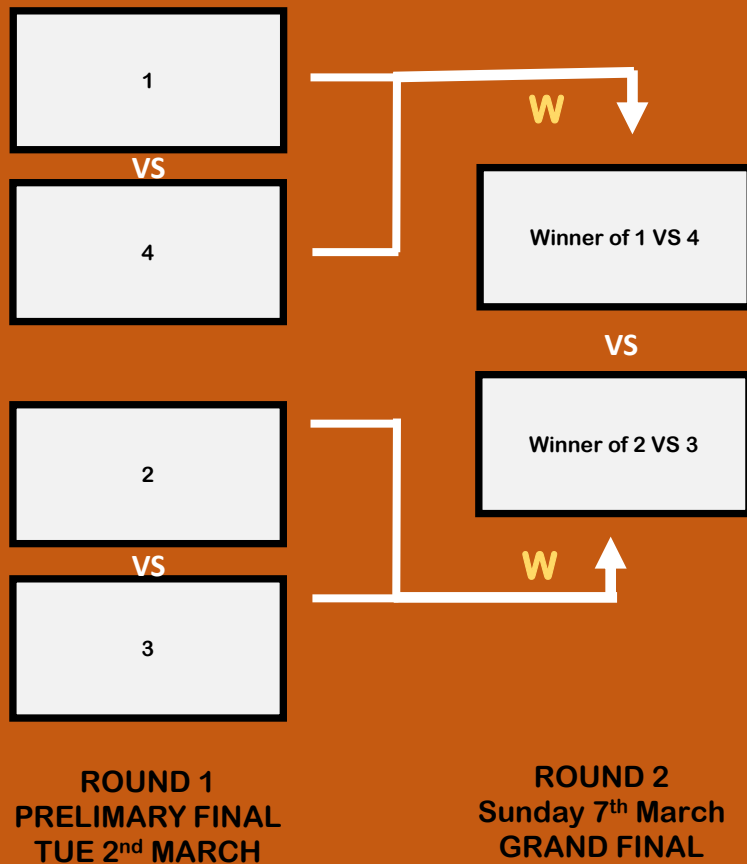

PATHWAY TO 2020/2021 GRAND FINAL TUESDAY MIXED DIV 1 PLATE, 2 PLATE & 3 PLATE

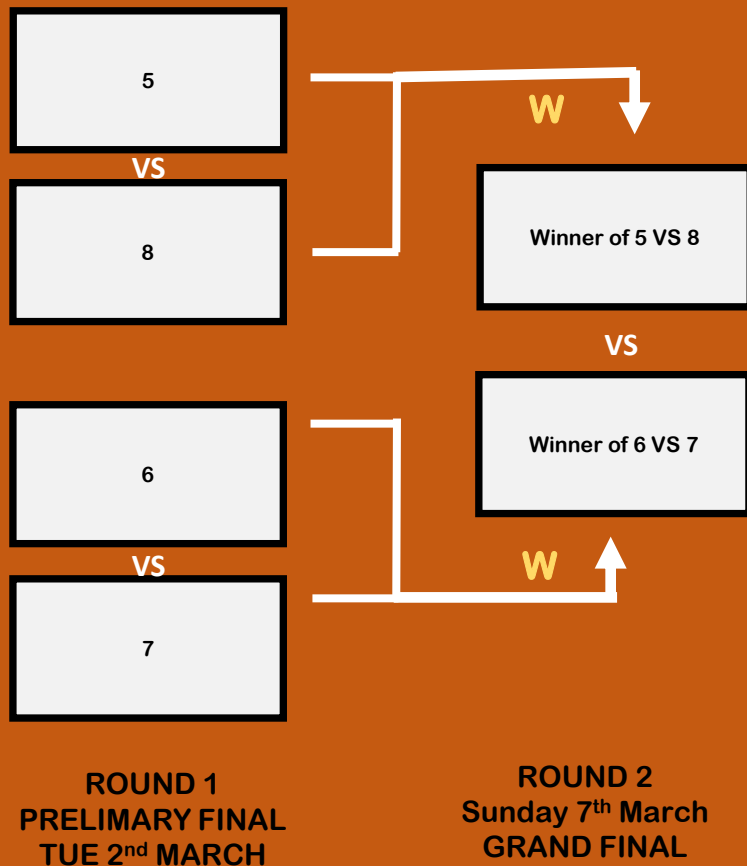

PATHWAY TO 2020/2021 GRAND FINAL MENS DIV 1 & 2 & MIXED LOW

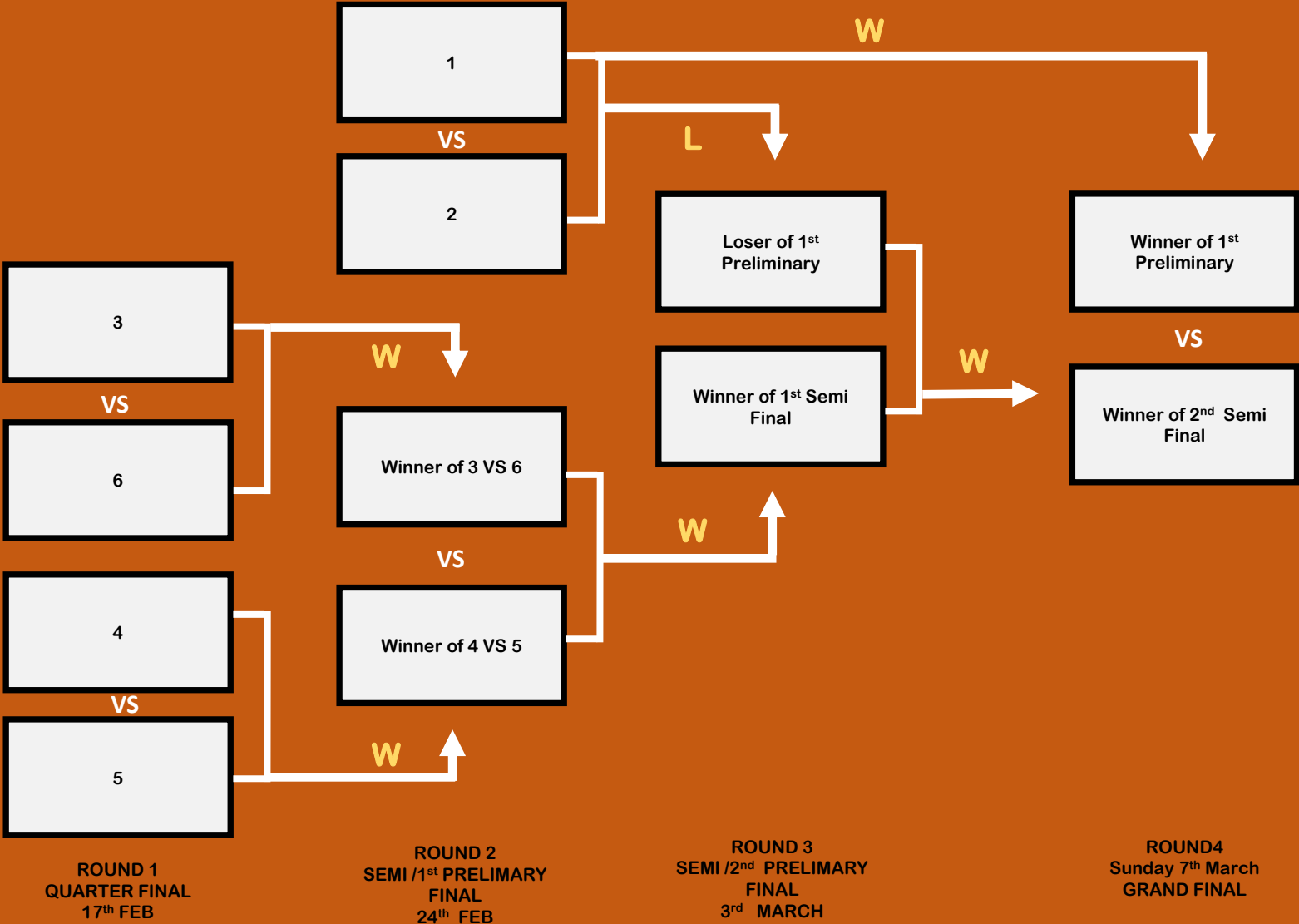

PATHWAY TO 2020/2021 GRAND FINAL WEDNESDAY MENS DIV 3

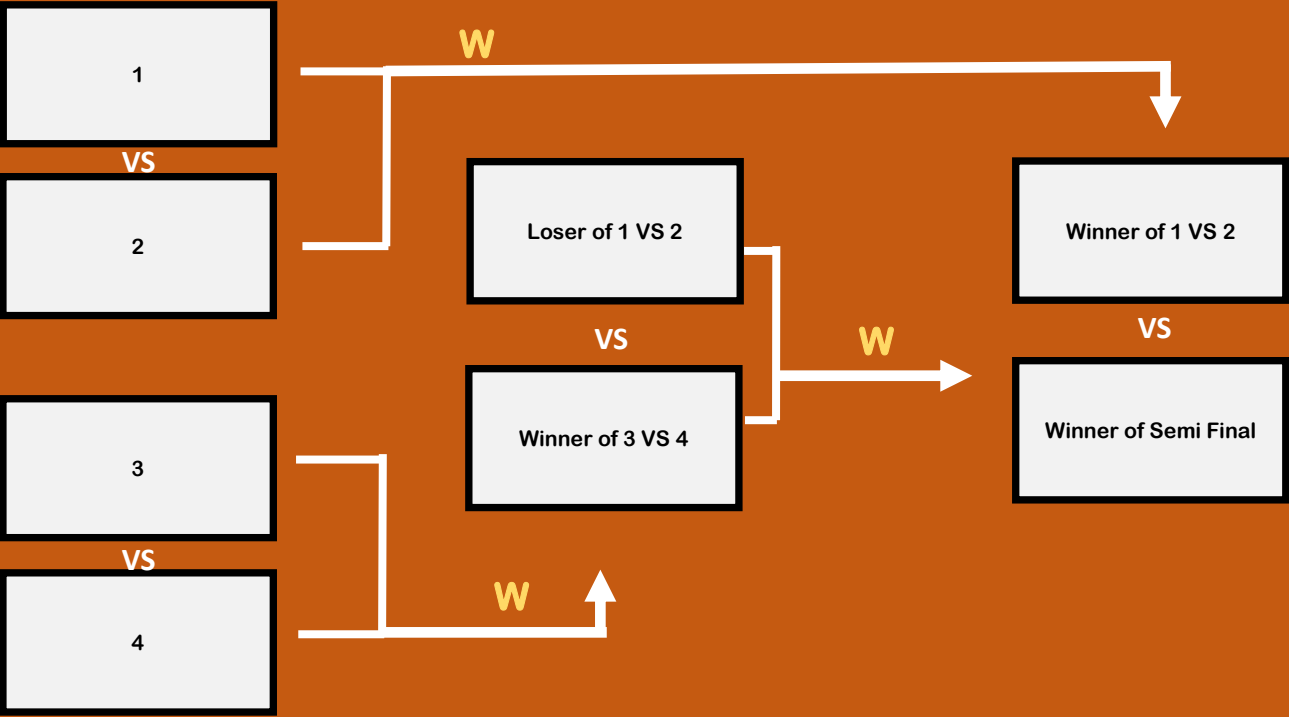

ROUND 1
QUARTER/PRELIMINARY
FINAL
Wed 17th FEB

ROUND 2
PRELIMINARY FINAL
Wed 24th FEB

ROUND 3
Sunday 7th March
GRAND FINAL



WET WEATHER IMPACTS

- Current Finals system is subject change due to weather and field availability.
- In the event of field closures, team progression throughout the finals series will be given to the highest rank teams.

Tuesday night all divisions

- In the event of field closures for finals round 1, Teams 1 & 2 would progress to Sunday Champions Trophy on Grand Final Day.
 - Teams 3 & 4 would compete for the Plate Trophy on Sunday Grand Final Day
 - Teams 5-8 would regrettably not participate in finals.

Wednesday night – Men's Div 1 & 2 & Mixed low

- In the event of field closures in any of the 3 finals rounds preceding the Grand Final, the remaining two lowest rank teams would drop out of the finals series and the remaining highest rank teams progressing to the next round.

Wednesday night – Men's Div 3

- Wednesday March 3rd remains as backup date for rounds 1 & 2. This date will be used in the event of field closures.
- Should both rounds 1 & 2 not proceed due to field closures, a standard 2 round finals series will be played (1vs4 & 2vs3) on backup date & Winners through to Sunday Grand Final Day. Should all 3 Wednesdays not proceed due to field closures Teams 1 & 2 would progress to Sunday Champions Trophy on Grand Final Day

